

		PAGES
<b>Product Overview</b> Description of SBS products	<b>1</b>	1-4
<b>Controls/ Electronics</b> Control units for all our balancers and related accessories	<b>2</b>	5-10
<b>External Balancers</b> Mounted at either end of the grinder spindle for easy installation	<b>3</b>	11-24
<b>Non-Contact Senders</b> Used to provide power to non-contact versions of external and internal balancers	<b>4</b>	25-27
<b>Internal Balancers</b> Mounted internal to the grinder spindle for minimum interference	<b>5</b>	28-34
<b>Acoustic Monitoring</b> AEMS system provides in process monitoring of grinding and dressing functions	<b>6</b>	35-43
<b>Vibration Sensors</b> Sensor options used with SBS equipment	<b>7</b>	44-45
<b>Hydrokompenser</b> Service parts for the original water type balance system	<b>8</b>	46-54



# PRODUCT CATALOG

**LL-5501**

Rev. 8/31/2010

**Copyright ©2010 by Schmitt Industries Inc.**

2765 NW Nicolai St.  
Portland OR 97210 USA  
Tel.: +1-503-227-7908  
Fax: +1-503-223-1258  
[www.schmitt-ind.com](http://www.schmitt-ind.com)

In Europe :

**Schmitt Europe Ltd.**

University of Warwick  
Science Park Ltd., Sir William Lyons Rd.  
Coventry, CV4 7EZ, England  
Tel.: +44-1203-597192  
Fax: +44-1203-412697

## Company

SBS has become a leader in its industry by listening and responding to our customers. We design, manufacture and market the most extensive line of balancers in the world to cover the diverse needs of our customers. We engineer our balancer applications to allow quick and easy installation, and provide trouble free service. The SBS AEMS acoustic monitoring product line allows precision control of grinding and dressing operations. We are dedicated to comprehensive customer service, and maintain an ample inventory of all products. SBS has proven itself a reliable partner to the grinding industry in over 15 years of service with excellence.

## Modular Control System

SBS produces a series of controls which integrate and standardize the operation all of our products. Our control system has taken balancing of grinding machines to a new level of accuracy (.02 microns), speed (300 to 30,000 RPM) and convenience. The bright, easy to read display puts more control and information at your fingertips. Quick setups and dynamic graphic displays provide superior control of the grinding process.

- 2 or 4 channel operation (each channel controls a separate device)
- Front panel keypad/display can be mounted remotely from control
- Variety of mounting hardware

## External Balancers

In the U.S., external balancers are the optimum solution for most grinding machines. SBS external balancers are easy to mount, highly reliable and require little operator training, making them exceedingly popular. They are designed as an inexpensive, permanent installation on grinding machines.

External Balancers use internal motors and precision gear trains to position two balance weights inside the unit, to compensate for unbalance in the spinning wheel/ spindle assembly.

Standard systems use a long life rotary slip ring power transfer system to send power to the spinning balancer. A Non-Contact Power transfer system is available as an option.

A system includes the Balancer needed for your application, a custom designed Adaptor for mounting the balancer, Control Unit, Vibration Sensor, Balancer Cable, and any needed tools or accessories.

- Easy to retrofit to existing grinders
- Mounts to either wheel end or pulley end of spindle
- Balance compensation range of 75 – 12,000 g·cm
- Operation from 300 – 13,000 rpm

## Internal Balancers

The Internal Balancer is a preferred choice by many European grinding machine builders. This balancer type is designed to fit inside the grinding spindle, in a bore supplied by the machine builder. The balance weights are located under the wheel, eliminating any possible lateral coupled forces on the spindle. Placement of the Balancer inside the spindle minimizes possible interferences between the Balancer and other machine components.

Internal Balancers use internal motors and precision gear trains to position two balance weights inside the unit, to compensate for unbalance in the spinning wheel/ spindle assembly. Power transfer systems are identical to external balancers, either long life rotary slip ring, or non-contact systems are available.

- Balance compensation range of 100 – 4,500 g·cm
- Operation from 300 – 13,000 rpm

## AEMS Monitoring System

This optional add-in card for the SBS control system offers our customers the capability to monitor their grinding process with exceptional precision.

The AEMS product uses proprietary acoustic sensor technology to monitor the very high frequency signals generated in the grinding machine structure during wheel contact in the grinding and dressing processes. The user can set up the system easily, and immediately reap the benefits of improved control.

AEMS can substantially eliminate grind cycle gap time (time required for wheel infeed prior to contact with the work piece). Gap time can add significantly to the overall part cycle time, reducing production efficiency.

The AEMS system provides detection of any crash contact immediately as it happens, providing input to the CNC control to stop wheel infeed.

Using the AEMS system, the user can set up minimum and maximum expected acoustic levels during normal wheel dressing. The operator or CNC control can then determine not only if the wheel is being dressed all the way across its width, but also can control the aggressiveness of the dressing process, and the resulting quality of the dressed wheel.

- Elimination of grinding cycle gap time
- Notification of crash conditions
- Monitoring wheel dressing

## Manual Balance Control

The Manual Balance Control is designed to measure unbalance in grinding machines, calculate the compensation needed to eliminate unbalance, and guide the user in making manual corrections to achieve balance. Balance is achieved by positioning the existing spread balance weights on the grinding



machine to calculated positions. This product provides a lower cost dedicated machine balancing alternative for applications which do not justify the cost of fully automatic control. The Manual Balance Control is based on the same rugged hardware as our high end automatic balance system control units, and can even be upgraded in the future to perform automatic balance control by adding the required control card.

## Balance System Purpose

The SBS control is used as part of a complete system which allows the user to monitor and correct for unbalance in grinding wheels and other types of rotating machinery. Balance is a critical process variable and even a small degree of unbalance can cause problems such as:

- Excess bearing wear and maintenance problems.
- High costs of premature grinding wheel and tool wear
- Poor quality control of work piece geometry and finish

## Sources of Unbalance

Unbalance is caused by many factors on a grinding machine, many of which are not static, but continually change as the grinder operates. Once a new wheel is initially balanced, balance will immediately begin to degrade due to these factors.

- Wheel wear
- Wheel dressing
- Coolant absorption
- New wheel installation

## System Operation Theory

A vibration sensor is mounted on the machine to monitor the machine's balance condition. The Control filters incoming vibration signals to the rotational frequency of the machine to measure the unbalance level, and correction of unbalance is provided by movement of the two compensating masses inside the Balancer mounted on the machine.

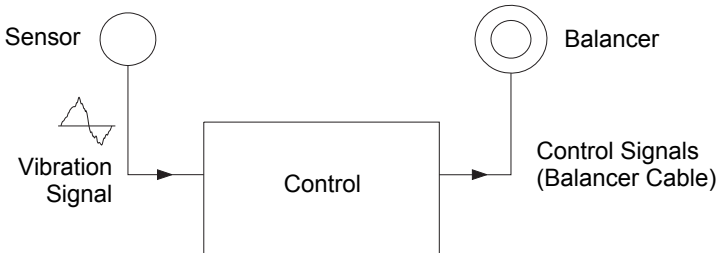

## System Components

A typical balance system consists of:

SB-14xx Vibration Sensor (xx= 11, 20, 40 ft. cable)[3.5m, 6.0m, 12m]

SB-55xx series Control (see control model table)

External, Internal, or Ring Balancer (see details under each product)

Balancer Cable (see details under balancer type)

Balancer mounting adaptor for specific grinder (contact SBS sales for details)

Optional control mounting hardware or other accessories

## Control Models

SBS control models are based on three configuration choices:

1. **Type of Balancer installed.** Specifies the type of device control card installed in device slot #1 when shipped. Each control card provides independent control of a single balancer or AEMS monitoring system. Additional device control cards can be ordered separately and installed as needed.
2. **110-220VAC Input or 24VDC Input.** Controls can be ordered in two configurations for the desired power input.
3. **Front Panel or Remote** display configuration. All controls can be shipped with a detachable Keypad/Display Panel as part of the control, or supplied in a Remote Configuration with no Front Panel. Operation of the control without front panel connected can be performed only via the software interface over USB or Ethernet
4. **Profibus or no Profibus option.** The standard control comes equipped with Profibus DP connectivity, or the control can be ordered without this interface.

### Control Model Table:

		110-220 AC Input		24VDC Input	
		Front Panel	No Panel	Front Panel	No Panel
Profibus	Standard External/ Internal	SB-5500	SB-5510	SB-5520	SB-5530
	Non-Contact External/ Internal	SB-5500-N	SB-5510-N	SB-5520-N	SB-5530-N
	Hydro Balancer	SB-5500-H	SB-5510-H	SB-5520-H	SB-5530-H
	AEMS Monitoring	SB-5500-G	SB-5510-G	SB-5520-G	SB-5530-G
No Profibus	Standard External/ Internal	SB-5501	SB-5511	SB-5521	SB-5531
	Non-Contact External/ Internal	SB-5501-N	SB-5511-N	SB-5521-N	SB-5531-N
	Hydro Balancer	SB-5501-H	SB-5511-H	SB-5521-H	SB-5531-H
	AEMS Monitoring	SB-5501-G	SB-5511-G	SB-5521-G	SB-5531-G
	Manual Balance	SB-5500-M	SB-5510-M	SB-5520-G	SB-5530-G



## Standard Control Features

- Operation of multiple SBS products in one unit
- Easy to use standard interface for all products
- Calibrated vibration reporting to 0.001 micron resolution
- NEMA 13/ IP 54 rated construction
- Individual hardwire interface for each device card (DB-25)
- Common software interface (via USB or Ethernet ports)
- Multi-language capable (English, Chinese, French, German, Spanish)
- Windows XP/Vista/Win7 compatible interface software available

## SB-5500 series Control

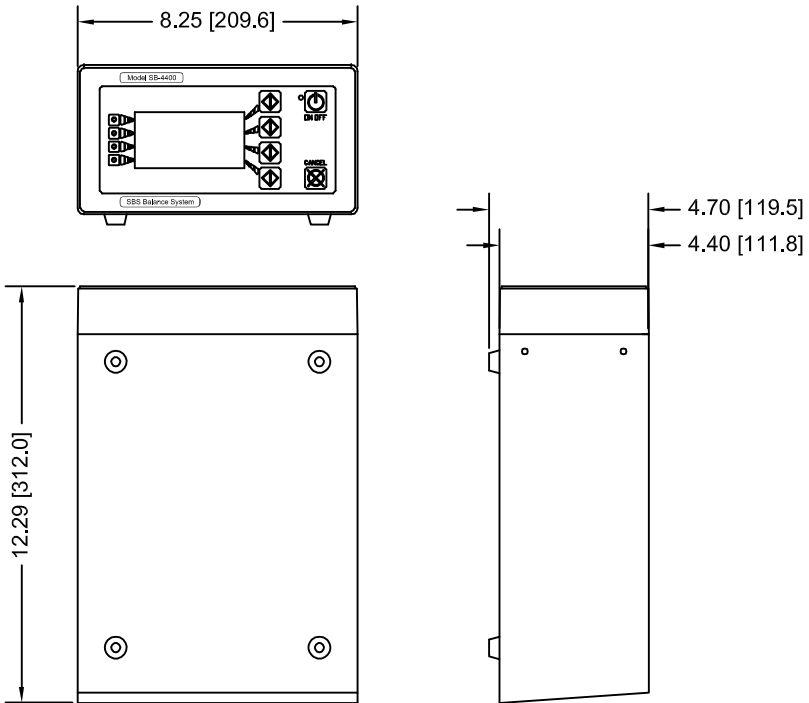

## Front Panel – Remote Mounting

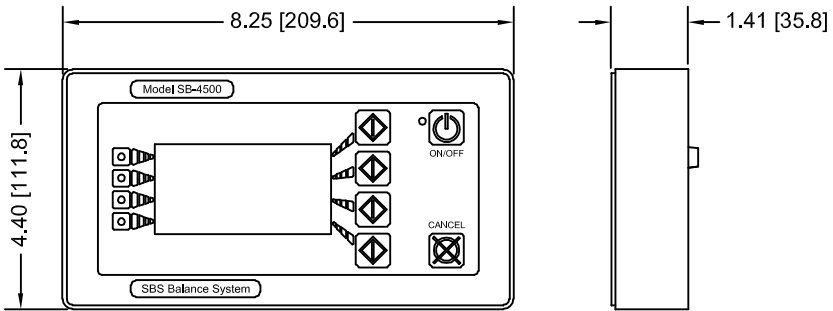

### Panel Mounting Requirements:

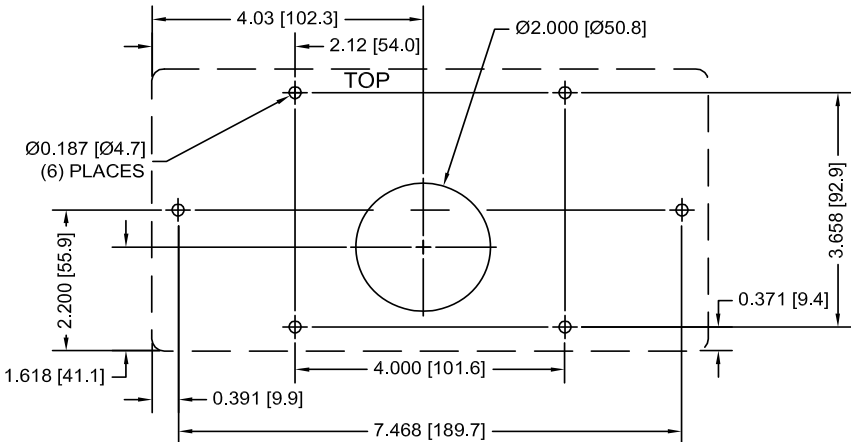

### SB-43xx Remote Display Cable

Cable required to connect the front panel display to the control unit, when the Front Panel is to be mounted separately.

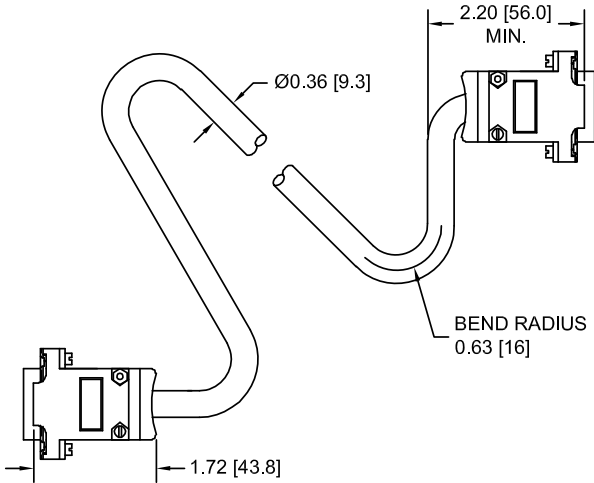

xx = 11, 20, 40 ft. cable length (3.5m, 6.0m, 12m)

## Additional Device Control Cards

These cards can be installed in empty slots in SBS Controls to provide control of multiple balancers with one control unit, or add AEMS acoustic monitoring control along with a balance system.

**Device Control Card Table**

Balancer Type	Card Part#
Standard External/ Internal	SB-5512
Non-Contact External/ Internal	SB-5532
Hydro Balancer	SB-5518
AEMS AE Monitoring	SB-5522
Manual Balance Control	SB-5543



## Hardwire Interface Cable

SB-24xx-L cable directly connects each device card in the SBS control to a PLC or other similar machine controller.

## Hardwire Interface Adaptors

These adaptors make it easy to update existing older balance systems to new SBS controls. These adaptors translate the standard I/O hardwire interface from common older balance controls to match the interface of the SB-4500 control family, eliminating the need to reprogram the PLC or machine control.

**Hardwire Interface Adaptor Table**

Control being replaced	Part#
HK-5000 Hydrokompenser	SB-4902
SB-2500 Mechanical Balancer	SB-4903

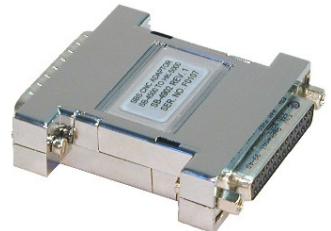

## External Balancer Models

External Balancers mount on the end of the machine spindle, using a mounting adaptor designed by SBS for each specific model of grinder. This mounting method allows for easy retrofit and installation.

External balancers are grouped into four basic connection types, which are pictured on the following pages. This connection type indicates the method of connecting the Balancer to the Balance Control unit.

**Type -F** – Remote cable connect

**Type -L** – Standard cable

**Type -V** – Heavy duty cable

**Type -N** – Non-Contact

**Type -G** – Non Contact with integral AEMS sensor

Type -N and -G balancers use non-contact inductive power transmission, and must be used with a Non-Contact Sender coil assembly.

<b>SB-</b>	<b>XXXX</b>	<b>-X</b>
	Model number (see table below)	Connection type (L,V,N,G)

Models	Case Type (see drawings)	Compensation (g*cm)
SB-0075-x	Low Mass	75
SB-0250-x		250
SB-0252-x		350
SB-0254-x		550
SB-0256-x		850
SB-0325-x	95mm	250
SB-0350-x		350
SB-0550-x		550
SB-0850-x		850
SB-1450-x	114mm	1450
SB-2550-x		2550
SB-3000-x		3000
SB-3700-x	130mm	3700
SB-5000-x		5000
SB-7500-x		7500
SB-9500-x	147mm	9500
SB-9800-x		12,000



**SB-0252-L** – Type L  
Standard cable



**SB-0254-V** – Type V  
Heavy duty cable



**Non-Contact Sender**  
**SB-8650-H** – side connection  
**SB-8660-H** – back connection



**SB-0550-N** – Type N  
Non-Contact



**Non-Contact Sender + AEMS**  
**SB-8650-I** – side connections  
**SB-8660-I** – back connections



**SB-0850-G** – Type G  
Non-Contact w/ AEMS sensor

## Low Mass Cable Models

Models	Compensation (g*cm)	Mount
SB-0075-x	75	6 x M3
SB-0250-x	250	6 x M3
SB-0252-x	350	6 x M3
SB-0254-x	550	6 x M3
SB-0256-x	850	6 x M3

### Type -L

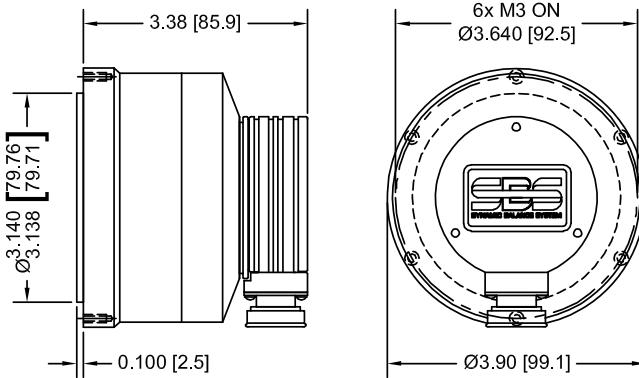

### Type -V

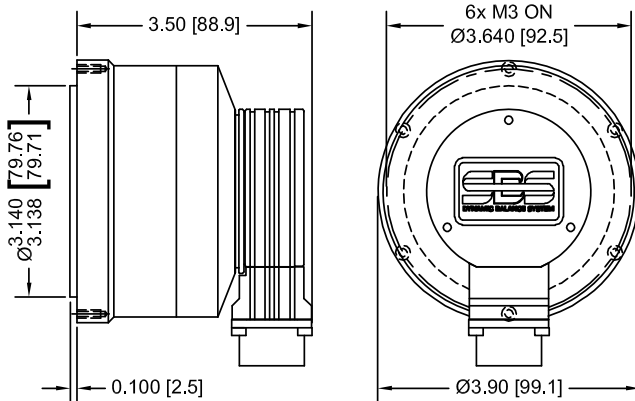

## Low Mass Non-Contact Models

Models	Compensation (g*cm)	Mount
SB-0075-x	75	6 x M3
SB-0250-x	250	6 x M3
SB-0252-x	350	6 x M3
SB-0254-x	550	6 x M3
SB-0256-x	850	6 x M3

### Type -N

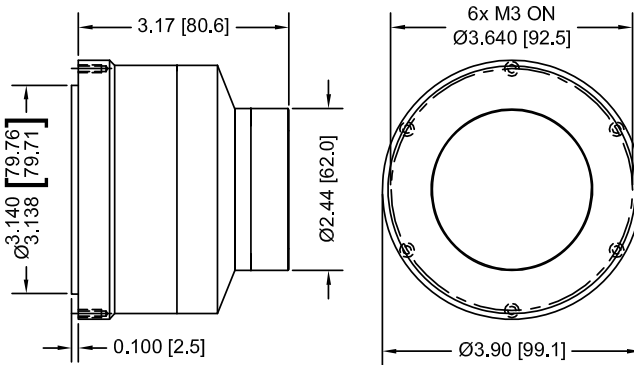

### Type -G

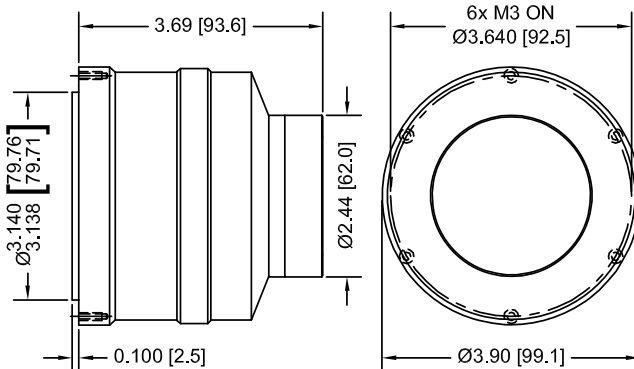

## Type –L Standard Cable Models

Models	A	B	C	D	Mount
SB-0325-L	3.740/3.738 [95 h7]	3.35 [85]	4.173 [106.0]	4.645 [118.0]	3 x M6
SB-0350-L					
SB-0550-L					
SB-0850-L	4.488/4.486 [114 h7]	3.35 [85]	4.960 [126.0]	5.433 [138.0]	3 x M6
SB-1450-L					
SB-2550-L					
SB-3000-L	5.118/5.116 [130 h7]	3.98 [101]	5.590 [142.0]	6.063 [154.0]	4 x M6
SB-3700-L					
SB-5000-L					
SB-7500-L	5.787/5.785 [147 h7]	3.98 [101]	6.312 [160.3]	6.750 [171.5]	4 x M6
SB-9500-L					
SB-9850-L					

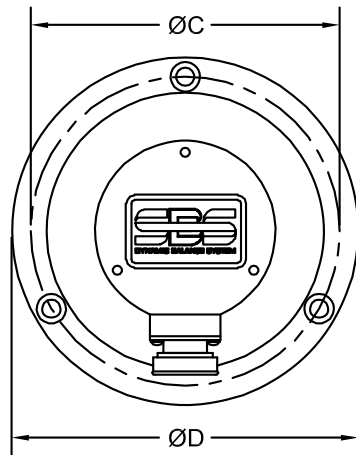
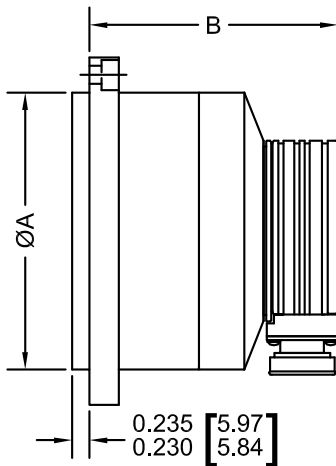

## Type –V Heavy Duty Cable Models

Models	A	B	C	D	Mount
SB-0325-V	3.740/3.738 [95 h7]	3.47 [88.1]	4.173 [106.0]	4.645 [118.0]	3 x M6
SB-0350-V					
SB-0550-V					
SB-0850-V					
SB-1450-V	4.488/4.486 [114 h7]	3.47 [88.1]	4.960 [126.0]	5.433 [138.0]	3 x M6
SB-2550-V					
SB-3000-V					
SB-3700-V	5.118/5.116 [130 h7]	4.08 [103.6]	5.590 [142.0]	6.063 [154.0]	4 x M6
SB-5000-V					
SB-7500-V					
SB-9500-V	5.787/5.785 [147 h7]	4.08 [103.6]	6.312 [160.3]	6.750 [171.5]	4 x M6
SB-9850-V					

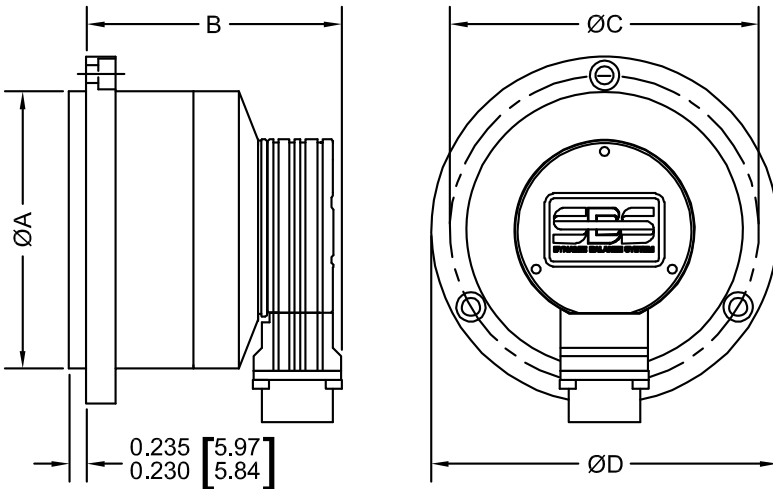

## Type –N Non-Contact Models

Models	A	B	C	D	Mount
SB-0325-N	3.740/3.738 [95 h7]	3.14 [79.8]	4.173 [106.0]	4.645 [118.0]	3 x M6
SB-0350-N					
SB-0550-N					
SB-0850-N					
SB-1450-N	4.488/4.486 [114 h7]	3.14 [79.8]	4.960 [126.0]	5.433 [138.0]	3 x M6
SB-2550-N					
SB-3000-N					
SB-3700-N	5.118/5.116 [130 h7]	3.77 [95.8]	5.590 [142.0]	6.063 [154.0]	4 x M6
SB-5000-N					
SB-7500-N					
SB-9500-N	5.787/5.785 [147 h7]	3.81 [96.8]	6.312 [160.3]	6.750 [171.5]	4 x M6
SB-9850-N					

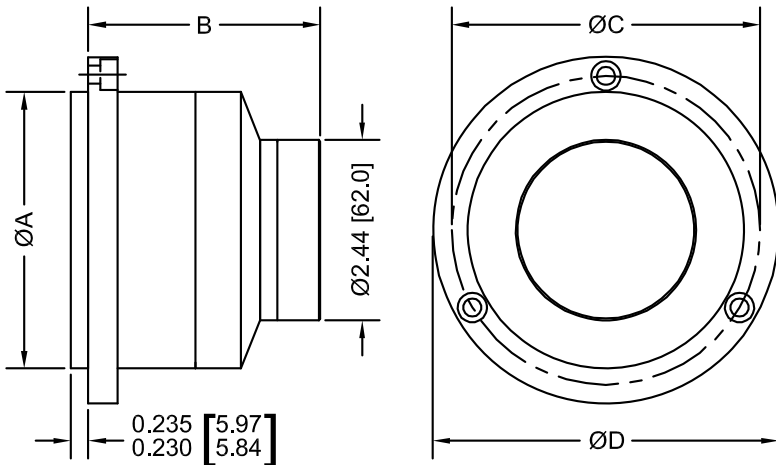

## Type –G Non-Contact + AEMS Models

Models	A	B	C	D	Mount
SB-0325-G	3.740/3.738 [95 h7]	3.65 [92.7]	4.173 [106.0]	4.645 [118.0]	3 x M6
SB-0350-G					
SB-0550-G					
SB-0850-G					
SB-1450-G	4.488/4.486 [114 h7]	3.65 [92.7]	4.960 [126.0]	5.433 [138.0]	3 x M6
SB-2550-G					
SB-3000-G					
SB-3700-G	5.118/5.116 [130 h7]	4.28 [108.7]	5.590 [142.0]	6.063 [154.0]	4 x M6
SB-5000-G					
SB-7500-G					
SB-9500-G	5.787/5.785 [147 h7]	4.32 [109.7]	6.312 [160.3]	6.750 [171.5]	4 x M6
SB-9850-G					

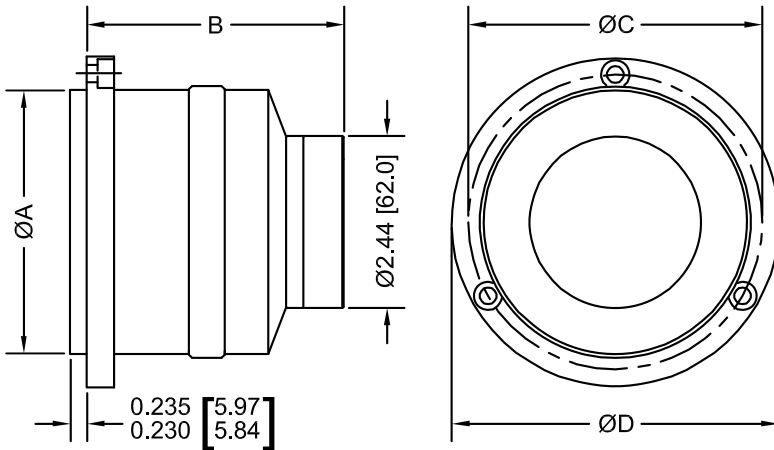

## Balancer Mounting Adaptors

Adaptors are designed to mount Balancers on a specific make and model of grinder.

SBS has an extensive list of pre-engineered solutions available. When required, SBS will custom design a new mounting adaptor for your application.

Most adaptors are a one or two part assembly. Two part designs (type 3,4,5,6) use a standard flange which holds the balancer, and mounts to a separate Adaptor Nut via a threaded connection. This quick change design allows the balancer to be easily removed from the machine for wheel changes or other requirements. Locking versions are required where grinders have speed controls or spindle brakes.

**For details on your machine model, please contact your SBS sales representative.**

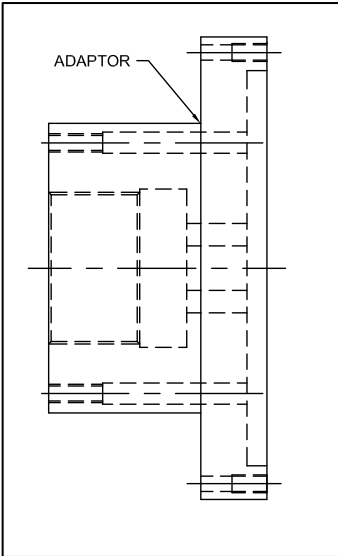

**One Part Adaptor**  
Type 1

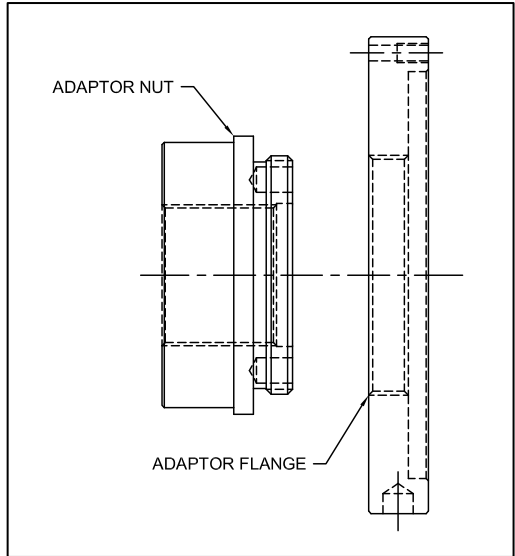

**Two Part Adaptor**  
Types 3,4,5,6

## Adaptor Type Descriptions:

- TYPE 1** One Part Adaptor
- TYPE 3** Two Part Adaptor - (3.000-12 LH thread connect - cw rotation)
- TYPE 4** Two Part Adaptor - (2.750-12 RH thread connect - counter-cw rotation)
- TYPE 5** Small Two Part Adaptor - (2.250-16 LH thread connect - cw rotation)
- TYPE 6** Small Two Part Adaptor - (2.000-16 RH thread connect - counter-cw rotation)

### Available Standard Adaptor Flanges for Two Part Adaptors

Balance Head	Flange Lock	Type 3	Type 4	Type 5	Type 6
SB-0250-L SB-0252-L SB-0254-L SB-0256-L	•			A-0146-B  A-0146-C	A-0800-B
SB-0325-L SB-0350-L SB-0550-L SB-0850-L	•	A-0018-B  A-0018-C	A-0064-B	A-0088-B  A-0088-C	A-0085-B
SB-1450-L SB-2550-L SB-3000-L	•	A-0026-B  A-0026-C	A-0111-B	A-0096-B  A-0096-C	A-0099-B
SB-3700-L SB-5000-L SB-7500-L	•	A-0048-B  A-0048-C	A-0104-B	A-0294-B  A-0294-C	
SB-9500-L SB-9800-L		A-0384-B	A-0434-B		

## Standard Cable

**SB-48xx** – Standard Balancer Cable: 12-pin M DIN > 7-pin F Bayonet  
 Connects SB-xxxx-L model Balancers to Balance Control  
 xx = 11, 20, or 40 (cable length in feet - 3.5m, 6.0m, 12m)

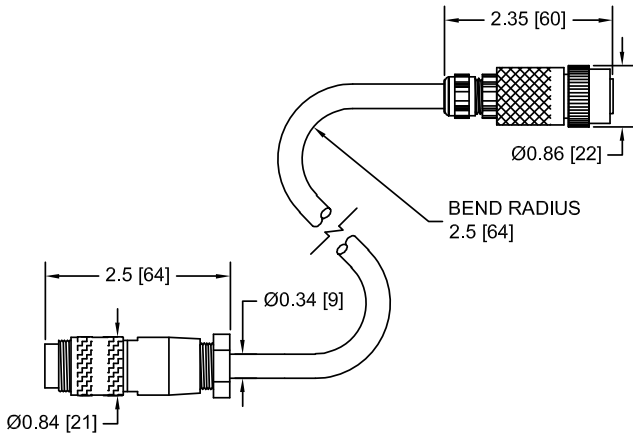

## Heavy Duty Cable

**SB-48xx-V** – Heavy Duty Balancer Cable: 12-pin M DIN > 7-pin F Bayonet  
 Connects SB-xxxx-V model Balancers to Control  
 xx = 11, 20, or 40 (cable length in feet - 3.5m, 6.0m, 12m)

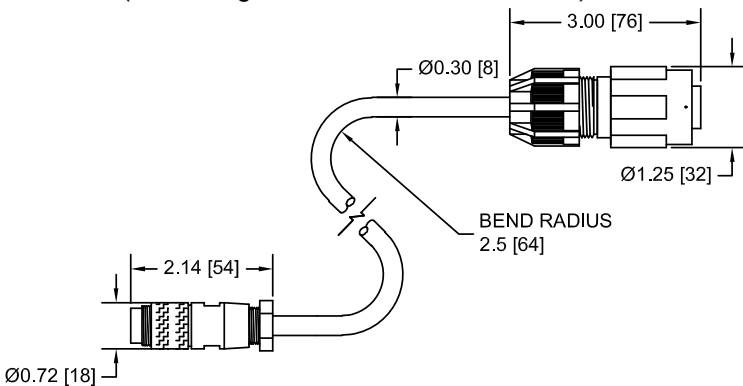

## Non-Contact Balancer Cable

**SB-87xx-H** – Non-Contact Balancer Cable: 8-pin M DIN > 8-pin F Bayonet  
 Connects Non-Contact Sender (SB-8650-x/ SB-8660-x) to Balance Control  
 xx = 11, 20, or 40 (cable length in feet - 3.5m, 6.0m, 12m)

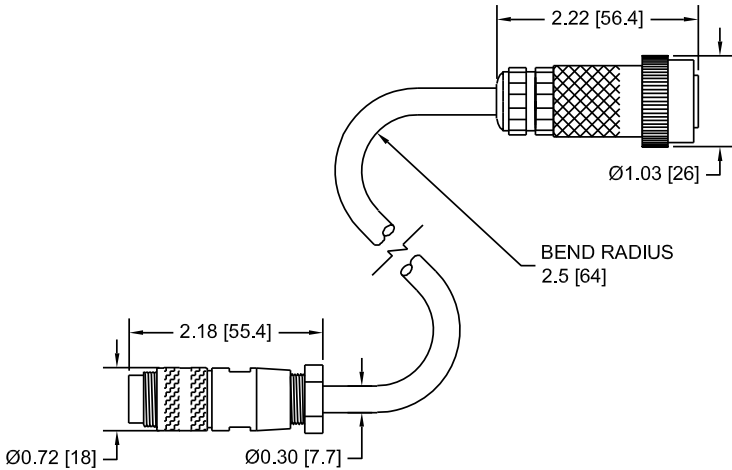

## Non-Contact AEMS Cable

**SB-41xx-I** – Non-Contact AEMS Cable: 4-pin M DIN > 3-pin F Bayonet  
 Connects Non-Contact Sender w/ AEMS (SB-8650-I/ SB-8660-I) to AEMS  
 Control Card in Control Unit.  
 xx = 11, 20, or 40 (cable length in feet - 3.5m, 6.0m, 12m)

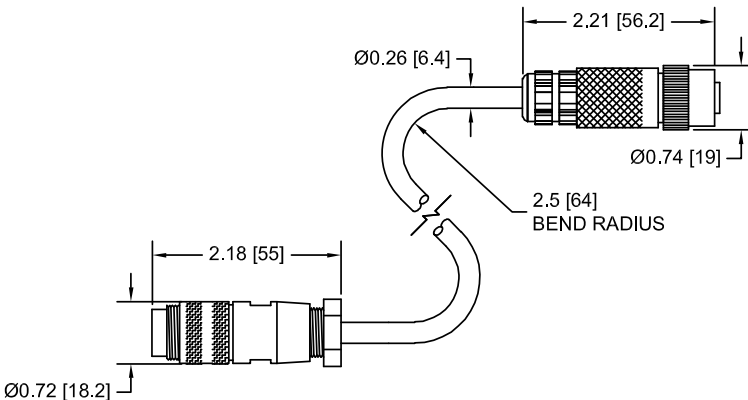

## Extension Cables

**SB-46xx** – Balancer Extension Cable: 12-pin M DIN > 12-pin F DIN  
 Extends cable run for SB-48xx and SB-48xx-V  
 xx = 11, 20, or 40 (cable length in feet - 3.5m, 6.0m, 12m)

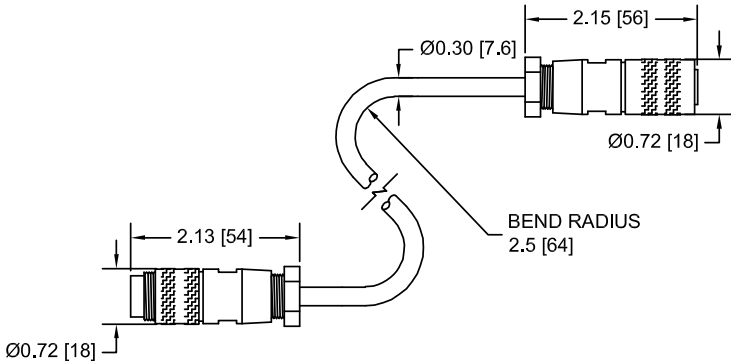

**SB-46xx-C** – Balancer Extension Cable: 12-pin M DIN > 12-pin F DIN  
 Extends cable run for SB-48xx and SB-48xx-V  
 Added strain relief for bulkhead pass-through  
 xx = 11, 20, or 40 (cable length in feet - 3.5m, 6.0m, 12m)

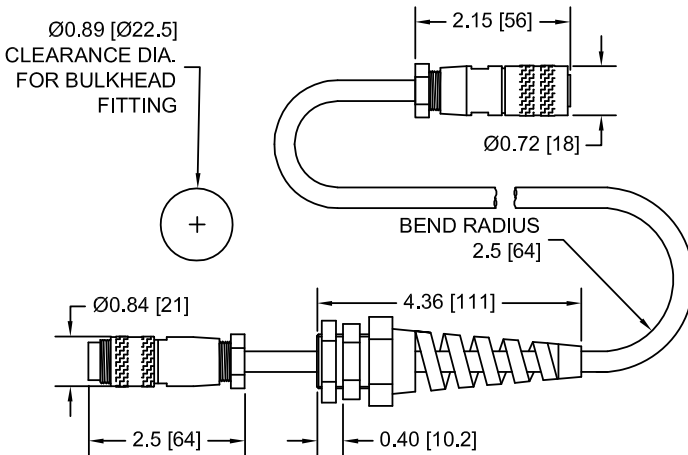

**SB-41xx** – AEMS Extension Cable: 4-pin M DIN > 4-pin F DIN  
 Extends cable run for SB-41xx-l  
 xx = 11, 20, or 40 (cable length in feet - 3.5m, 6.0m, 12m)

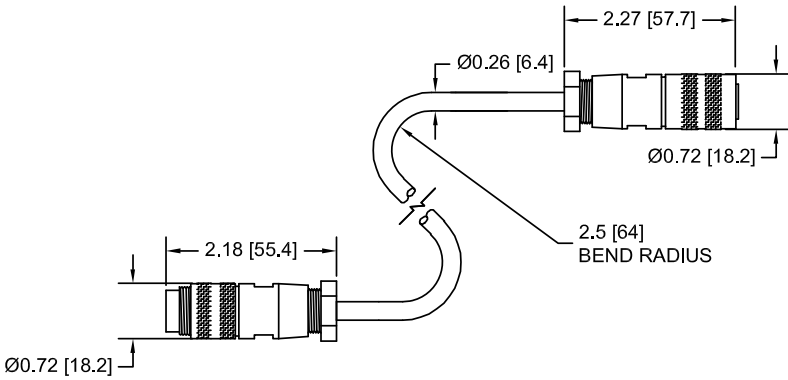

## Balancer Only Models

The Non-Contact Sender is used with both External and Internal type Non-Contact Balancers. Connection to the Balance Control is made via. SB-87xx-H cable.

The Sender is mounted on a stationary part of the grinder, so that the round coil face is opposite the matching receiving coil face on the Balancer.



### SB-8650-H – Side Connection

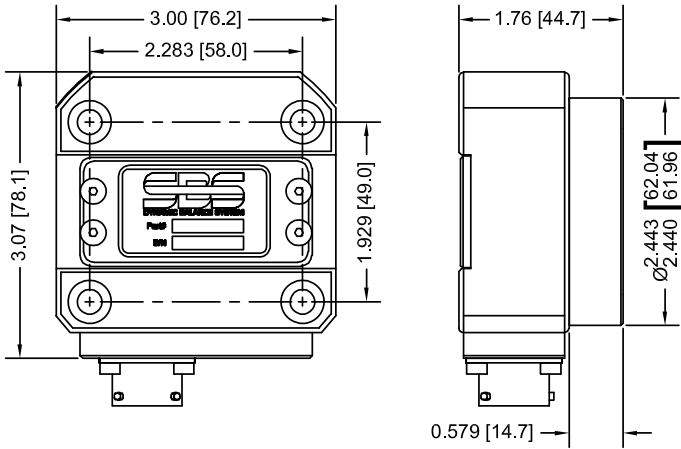

### SB-8660-H – Back Connection

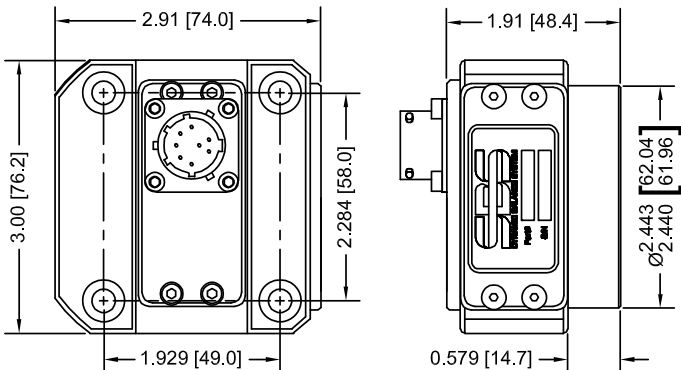

## Balancer + AEMS Models

The Non-Contact Sender is used with External and Internal Non-Contact Balancers with integrated AEMS (AE Monitoring) Sensor. Connection to the Balance Control unit is via SB-87xx-H cable. Connection to the AEMS control card mounted in the Control Unit is via SB-41xx-I cable.

The Sender is mounted on a stationary part of the grinder, so that the round coil face is opposite the matching receiving coil face on the Balancer.



### SB-8650-I – Side Connection

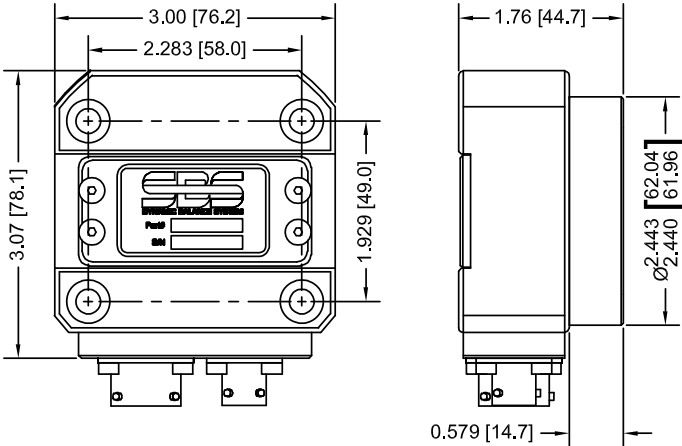

### SB-8660-I – Back Connection

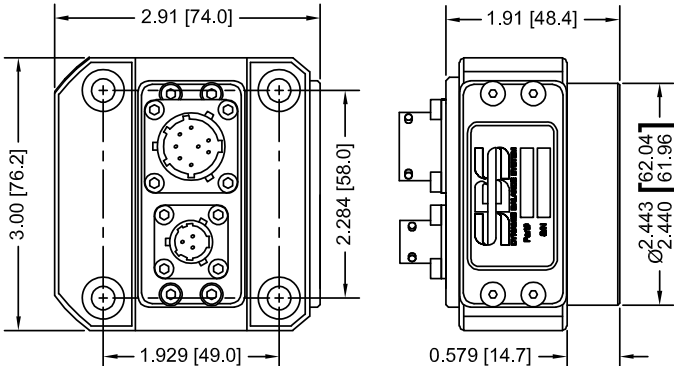

## Installation

In Non-contact applications, the Sender unit must be mounted to a fixed portion of the grinder, often the machine guard when the balancer is mounted on the wheel end of the spindle. The standard mounting kit provides a flexible mounting option for most installations.

The customer may create their own mounting method for some applications. At installation, the Sender unit must be aligned to the receiving coil on the Balancer within the following specifications.

- Distance between faces = 0.120 / 0.020 [3.0 / 0.5mm]
- Radial offset = 0.080 [2.0mm] max.

### MC-8606 – Non-Contact Sender Mount Kit

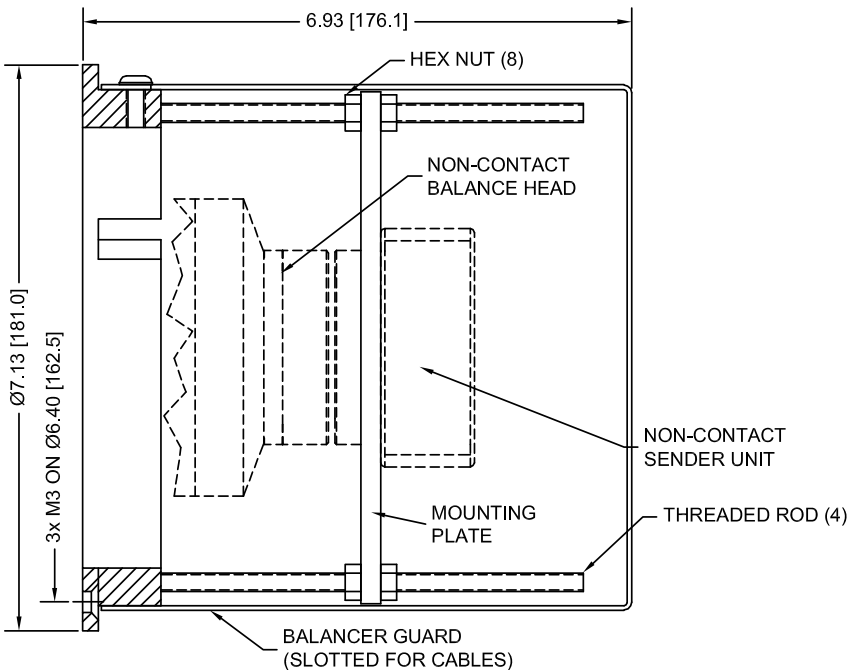

## Internal Balancer Models

The SBS internal balancer is the solution for grinding machines where the balancer needs to be “out of the way”. It is designed to fit into the grinding spindle, in a bore supplied by the machine builder. The balance weights are designed with an “over/under” configuration which eliminates dynamic couple when the balance weights are positioned under the wheel.

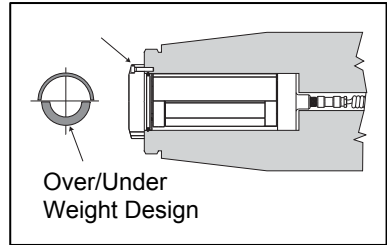

Power transmission to the balancer is provided in two basic methods.

**Rear Power** type balancers are most common, and use a remote power transmitter unit, mounted separately at the rear end of the spindle, and connected via cable to the balancer.

**Front Power** type balancers have the power transmitter assembly attached directly to the front of the balancer.

Both Rear and Front power type models are available with either a maintenance free Slip Ring power transmitter or with a Non-Contact transmitter system. The non-contact system can also accommodate an optional integrated AEMS sensor in the balancer.

Part numbers are application specific. Systems have an IA-xxxx application number, which includes the balancer, power transmitter and any additionally supplied components such as an in-spindle cable, mounting hardware, etc. For design consultation, please contact SBS.



Front Power with  
Non-Contact Transmitter



Rear Power with  
Slip Ring Transmitter

## Rear Power Models

A complete IA-xxxx Internal Balancer is a kit which consists of balancer, power transmitter, and spindle specific mounting parts. The following chart shows the standard rear power type balancer subcomponents available, for reference in planning of new applications. Please contact SBS for application assistance.

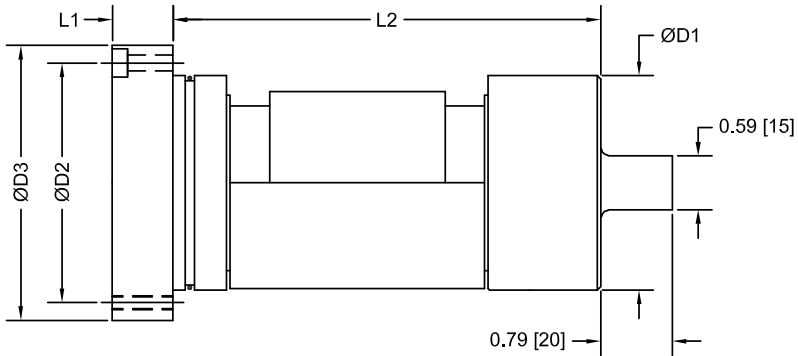

D1 mm [In]	D2 mm [In]	D3 mm [In]	L1 mm [In]	L2 mm [In]	Mounting	Capacity gm*cm
38 f6 [1.4951] [1.4945]	44.0 [1.732]	52 [2.05]	7 [0.28]	108 [4.25]	4 x M3	100
38 f6 [1.4951] [1.4945]	44.0 [1.732]	52 [2.05]	7 [0.28]	108 [4.25]	4 x M3	200
50 f6 [1.9673] [1.9667]	58.0 [2.283]	68 [2.68]	17 [0.67]	120 [4.73]	3 x M4	400
50 f6 [1.9673] [1.9667]	58.0 [2.283]	68 [2.68]	17 [0.67]	160 [6.30]	3 x M4	700
50 f6 [1.9673] [1.9667]	58.0 [2.283]	68 [2.68]	17 [0.67]	160 [6.30]	3 x M4	1400
60 f6 [2.3610] [2.3603]	67.0 [2.638]	77 [3.03]	17 [0.67]	120 [4.73]	4 x M4	800
60 f6 [2.3610] [2.3603]	67.0 [2.638]	77 [3.03]	17 [0.67]	160 [6.30]	4 x M4	2700
70 f6 [2.7547] [2.7540]	80.0 [3.150]	92 [3.62]	17 [0.67]	160 [6.30]	4 x M5	4500

## Rear Power Transmitters

These standard power transmitter subcomponents are available for integration into IA-xxx Internal Balancer kits. Subcomponents are listed for reference in planning of new applications. Please contact SBS for application assistance

Rear Power Slip Ring Transmitter

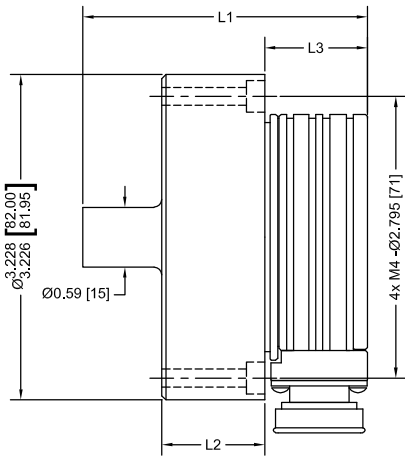

Rear Power Non-Contact Transmitter

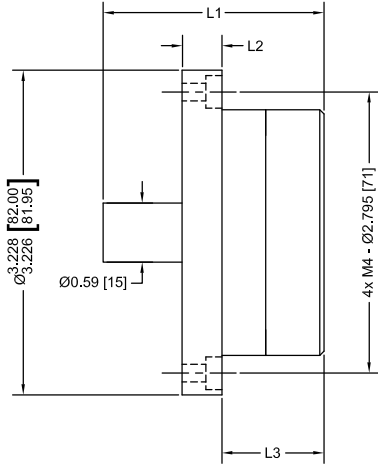

	<b>IK-0002 Slip Ring</b>	<b>IK-0004-N Non-Contact</b>	<b>IK-0004-G Non-Contact w/ AE Sensor</b>
L1	2.83 [72]	2.20 [56]	2.82 [71.7]
L2	1.02 [26]	0.39 [10]	0.93 [23.7]
L3	1.02 [26]	1.02 [26]	1.14 [29]

## Non-Contact Front Power Models

A complete IA-xxxx Internal Balancer is a kit which includes balancer, power transmitter, and spindle mounting parts. The following chart shows standard Non-Contact front power balancer subcomponents available, for reference in planning of new applications. Contact SBS for application assistance.

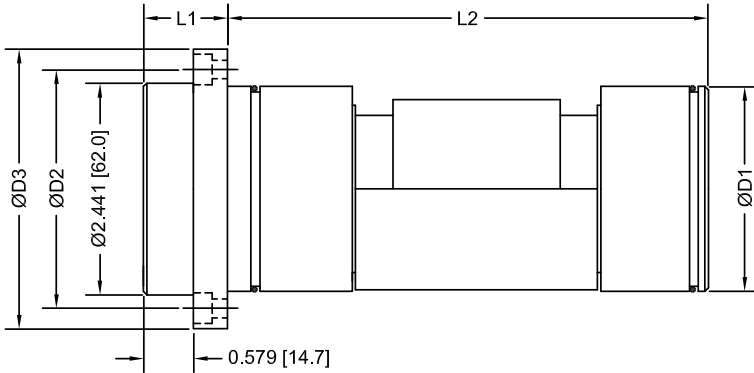

D1	D2	D3	L1	L2	L2 (w/ AEMS)	Mount	Capacity
mm [In]	mm [In]	mm [In]	mm [In]	mm [In]	mm [In]		gm*cm
38 f6 [1.4951] [1.4945]	68.0 [2.677]	76 [2.05]	30.7 [1.21]	103 [4.06]	110 [4.33]	4 x M3	100
38 f6 [1.4951] [1.4945]	68.0 [2.677]	76 [2.05]	30.7 [1.21]	103 [4.06]	110 [4.33]	4 x M3	200
50 f6 [1.9673] [1.9667]	70.0 [2.756]	80 [3.15]	30.7 [1.21]	130 [5.12]	145 [5.71]	3 x M4	400
50 f6 [1.9673] [1.9667]	70.0 [2.756]	80 [3.15]	30.7 [1.21]	170 [6.30]	185 [7.28]	3 x M4	700
50 f6 [1.9673] [1.9667]	70.0 [2.756]	80 [3.15]	30.7 [1.21]	170 [6.30]	185 [7.28]	3 x M4	1400
60 f6 [2.3610] [2.3603]	70.0 [2.756]	80 [3.15]	24.7 [0.97]	138 [5.43]	153 [6.02]	4 x M4	800
60 f6 [2.3610] [2.3603]	70.0 [2.756]	80 [3.15]	24.7 [0.97]	178 [7.01]	193 [7.60]	4 x M4	2700
70 f6 [2.7547] [2.7540]	80.0 [3.150]	92 [3.62]	24.7 [0.97]	178 [7.01]	193 [7.60]	4 x M5	4500

## Standard Cable

**SB-48xx** – Standard Balancer Cable: 12-pin M DIN > 7-pin F Bayonet  
 Connects Slip Ring model Balancers to the Balance Control  
 xx = 11, 20, or 40 (cable length in feet - 3.5m, 6.0m, 12m)

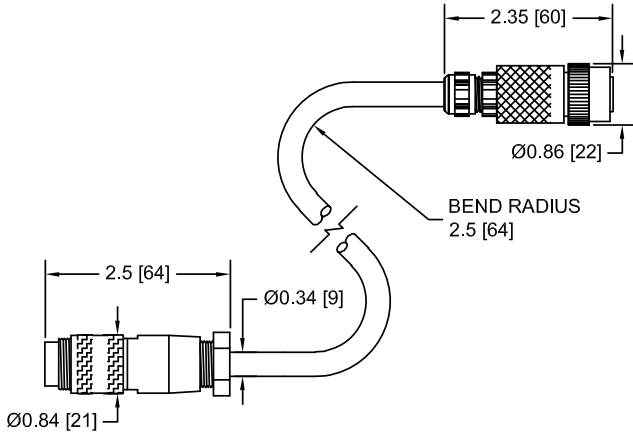

## Non-Contact Cable

**SB-87xx-H** – Non-Contact Balancer Cable: 8-pin M DIN > 8-pin F Bayonet  
 Connects Non-Contact Sender (SB-8650-x/ SB-8660-x) to Balance Control  
 xx = 11, 20, or 40 (cable length in feet - 3.5m, 6.0m, 12m)

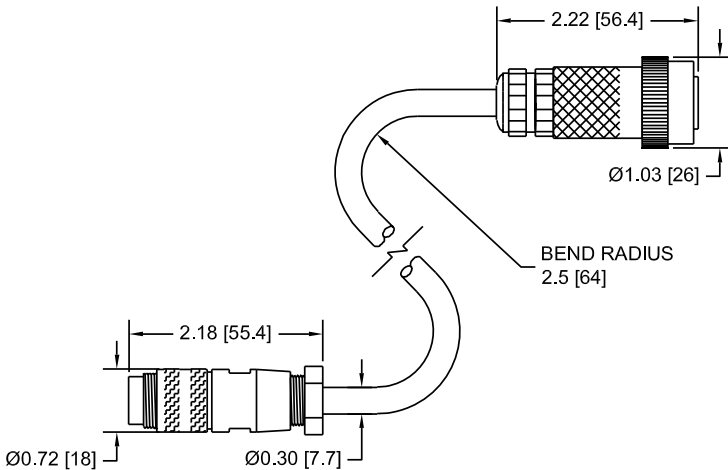

## Extension Cables

**SB-46xx** – Balancer Extension Cable: 12-pin M DIN > 12-pin F DIN

Extends cable run for SB-48xx

xx = 11, 20, or 40 (cable length in feet - 3.5m, 6.0m, 12m)

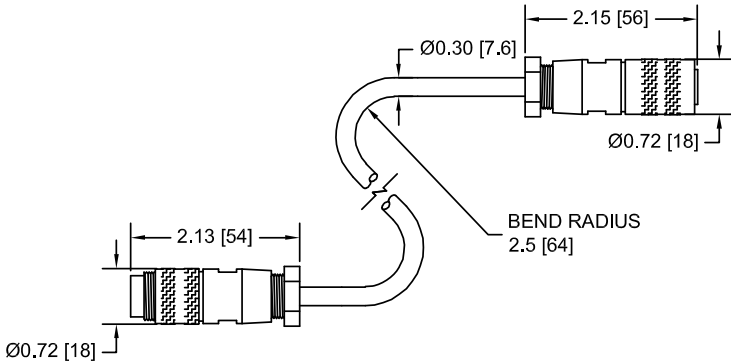

**SB-46xx-C** – Balancer Extension Cable: 12-pin M DIN > 12-pin F DIN

Extends cable run for SB-48xx

Added strain relief for bulkhead pass-through

xx = 11, 20, or 40 (cable length in feet - 3.5m, 6.0m, 12m)

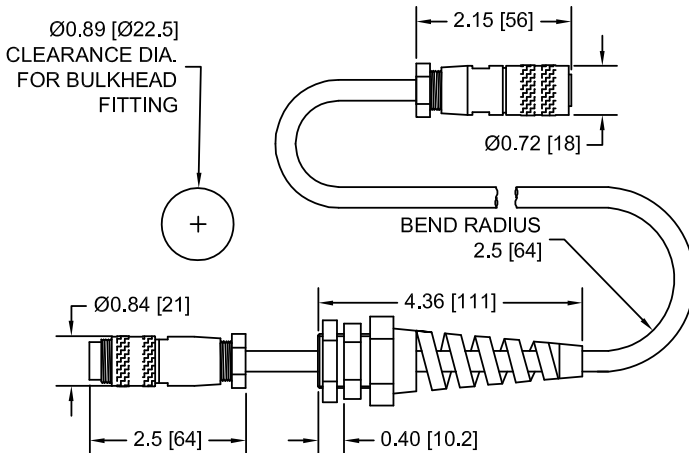

**SB-87xx** – Non-Contact Extension Cable: 8-pin M DIN > 8-pin F DIN  
Extends cable run for SB-87xx-H  
xx = 11, 20, or 40 (cable length in feet - 3.5m, 6.0m, 12m)

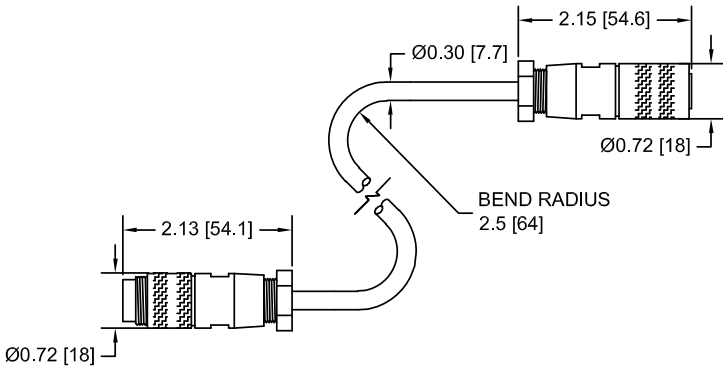

## AEMS System Card

This optional add-in card for the SBS control system offers our customers the capability to monitor their grinding process with exceptional precision.

The AEMS product uses proprietary acoustic sensor technology to monitor the very high frequency signals generated in the grinding machine structure during wheel contact in the grinding and dressing processes.



Key process events which can be addressed include:

- Substantial reduction of grinding cycle gap time
- Notification of crash conditions
- Monitoring wheel dressing

A variety of AE sensors are available, which cover the needs of different types of applications. These sensors are listed separately following.

## Stud Mount Non-Contact Sensors

**SB-3208** – AE Sensor: Non-contact spindle mounted  
Mini-Stud Mount – M6x1.0 LH  
(use with SB-3230/ SB-3231 Receivers)



**SB-3209** – AE Sensor: Non-contact spindle mounted  
Mini-Stud Mount – M6x1.0 RH  
(use with SB-3230/ SB-3231 Receivers)

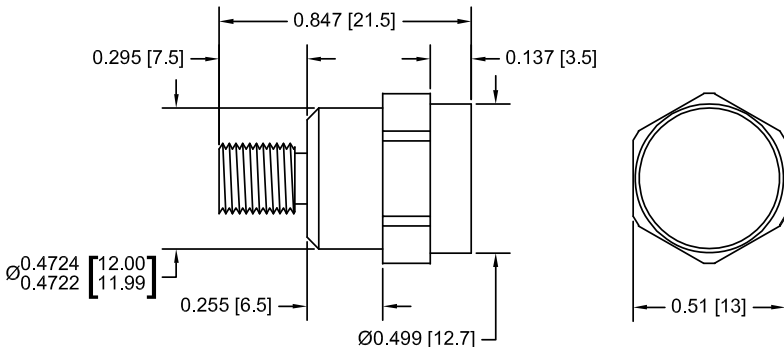

## Bolt On Sensors

**SB-42xx** – Bolt on AE Sensor w/ Cable: 4-pin M DIN  
 Sensor bolts directly to stationary portions of machine structure.  
 xx = 11, 20, or 40 (cable length in feet - 3.5m, 6.0m, 12m)

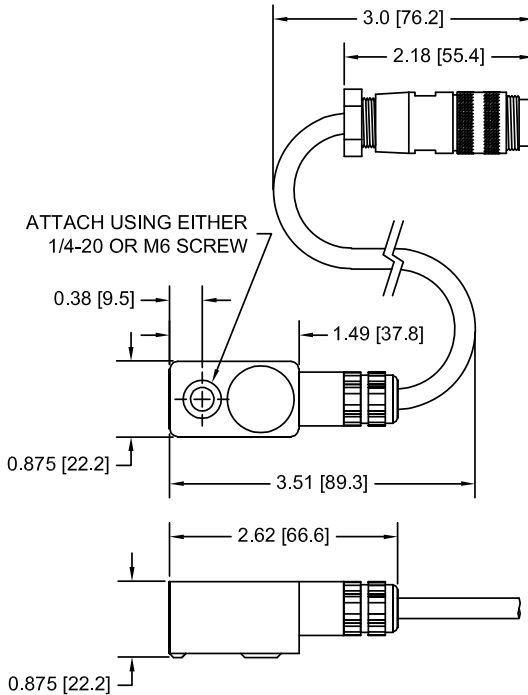

**SB-42xx-C** – Bolt on AE Sensor w/ Cable: 4-pin M DIN  
 Sensor bolts directly to stationary portions of machine structure.  
 Added strain relief for bulkhead pass-through  
 xx = 11, 20, or 40 (cable length in feet - 3.5m, 6.0m, 12m)

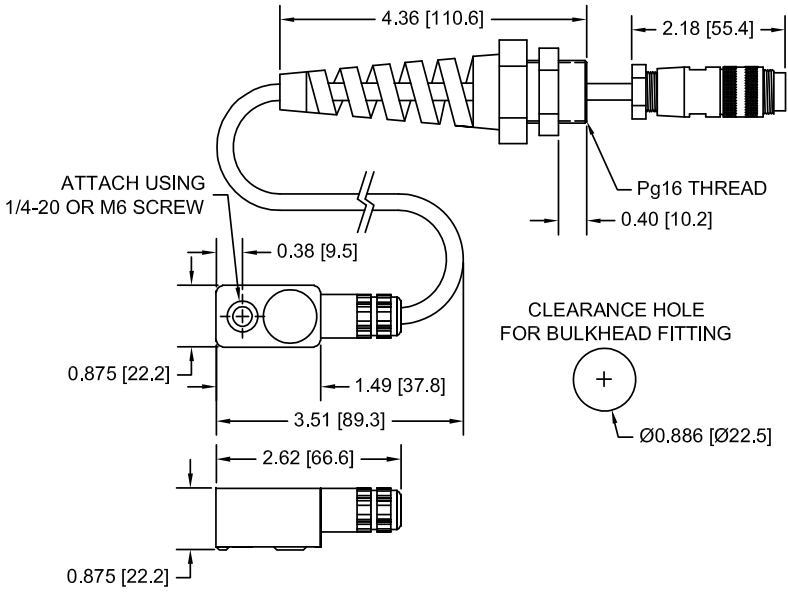

## In Spindle Non-Contact Sensors

**SB-3225** – AE Sensor/ Sender Package: Non-Contact In-Spindle  
(use with SB-3230/ SB-3231 Receivers)

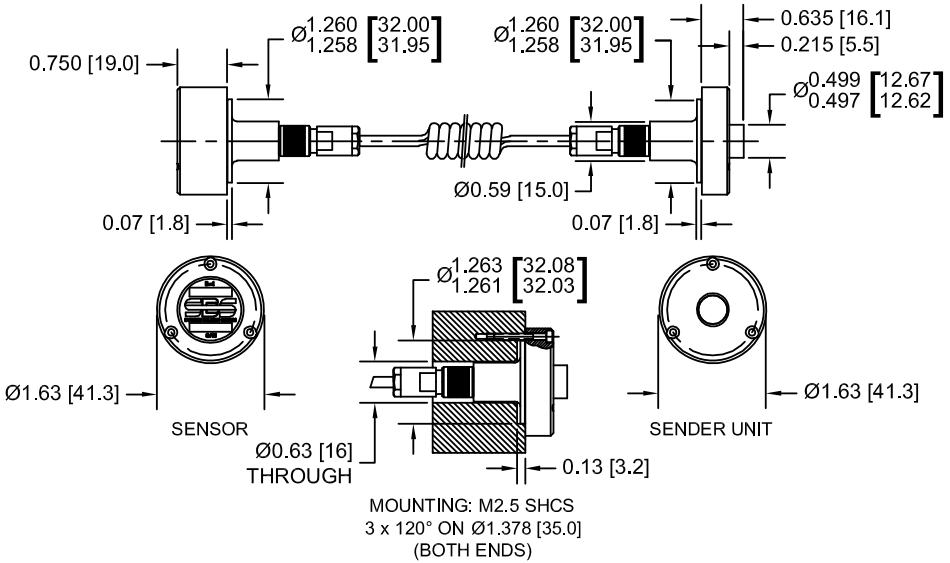

**SB-3210** – AE Sensor: Non-Contact In-Spindle w/ slide tube connection. Slide Tube extends to ease connection at installation, but should be near minimum length when operating. (use with SB-3213/ SB-3214 Senders, and SB-3230/ SB-3231 Receivers)

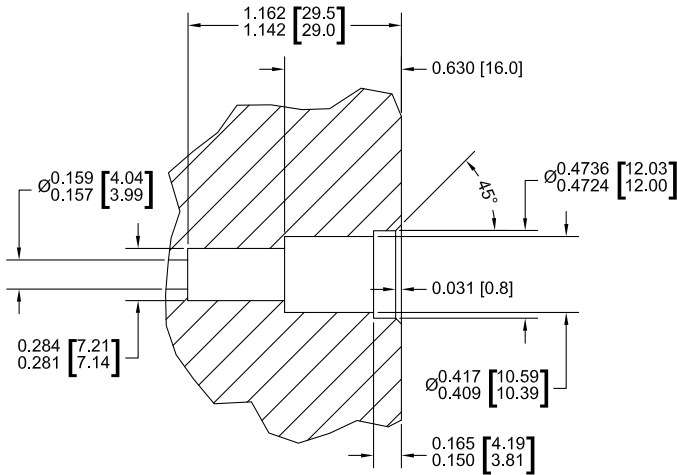
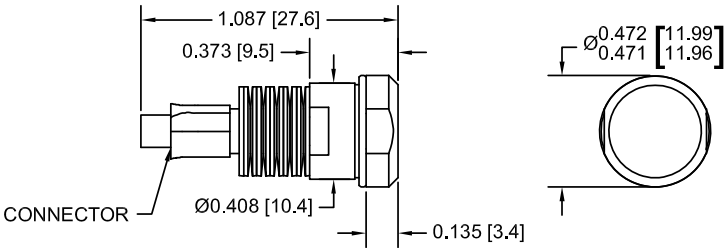

Mounting requirements for SB-3210

## N/C Sender – Slide Tube Connect

**SB-3213, SB-3214** – AE Sender: Non-Contact In-Spindle w/ slide tube connection. Slide Tube extends to ease connection at installation, but should be near minimum length when operating.  
 (use with SB-3210 Sensor, and SB-3230/ SB-3231 Receivers)

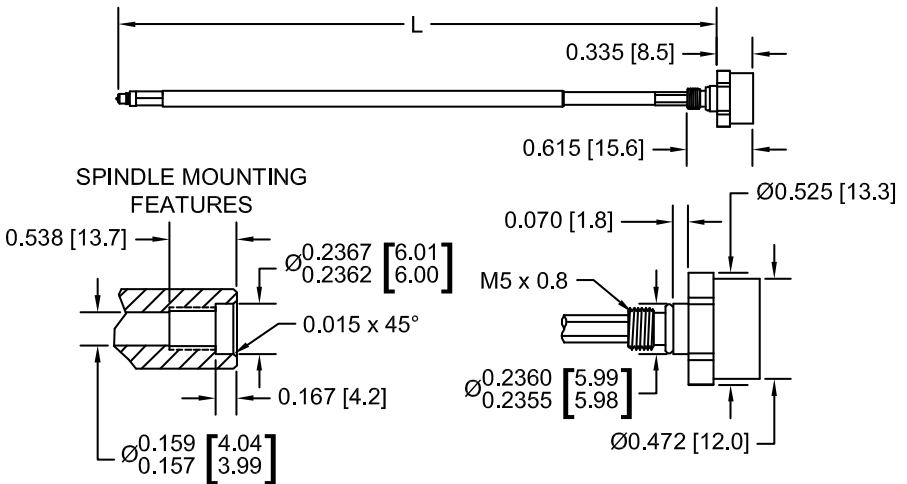

	Part#	
	SB-3213	SB-3214
L max./min.	7.00/5.25 [177/133]	11.50/9.75 [292/247]

## Non-Contact Sensor Receivers

**SB-3230** – AE Sensor Receiver: Non-Contact, Side Cable exit  
(use with all Non-Contact Sensors)

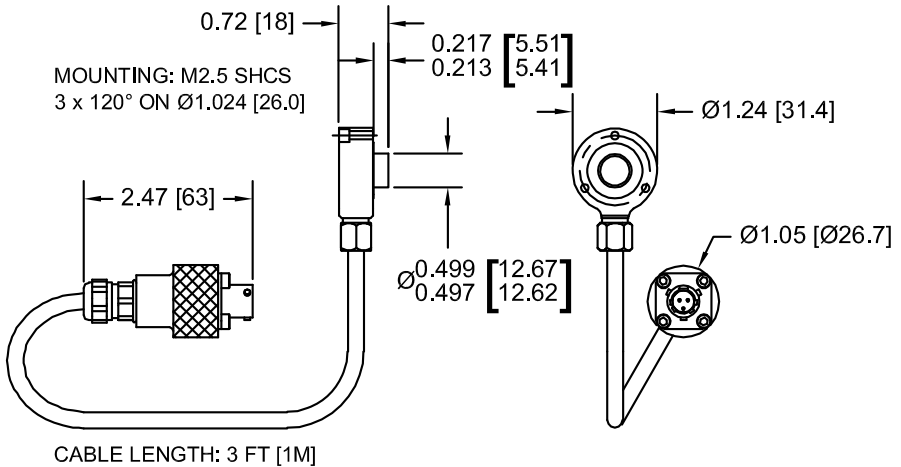

**SB-3231** – AE Sensor Receiver: Non-Contact, Back Cable exit  
(use with all Non-Contact Sensors)

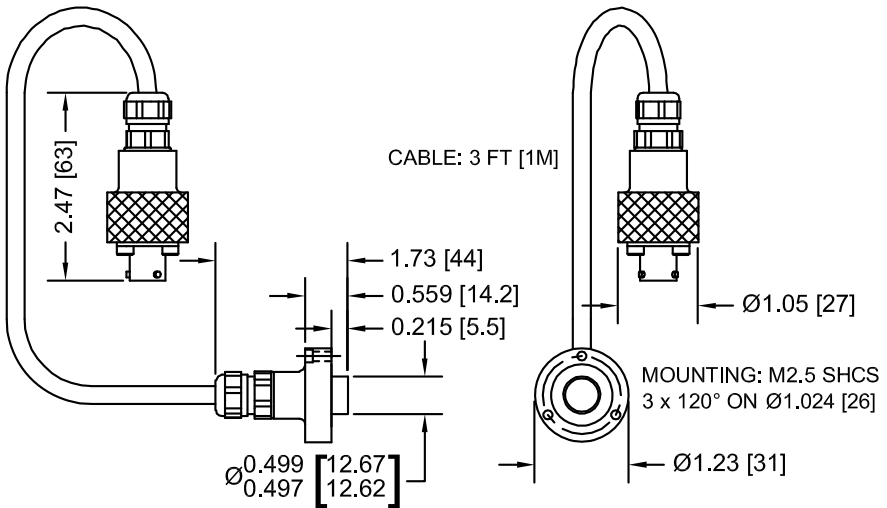

## Extension Cables

**SB-41xx** – AEMS Extension Cable: 4-pin M DIN > 4-pin F DIN

Extends cable run for SB-42xx

xx = 11, 20, or 40 (cable length in feet - 3.5m, 6.0m, 12m)

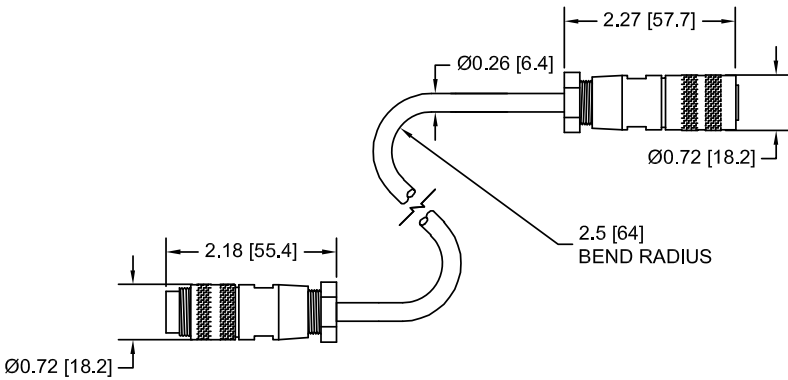

**SB-41xx-I** – Non-Contact AEMS Cable: 4-pin M DIN > 3-pin F Bayonet

Extends cable run for SB-3230, SB-3231 Non-Contact Receivers.

xx = 11, 20, or 40 (cable length in feet - 3.5m, 6.0m, 12m)

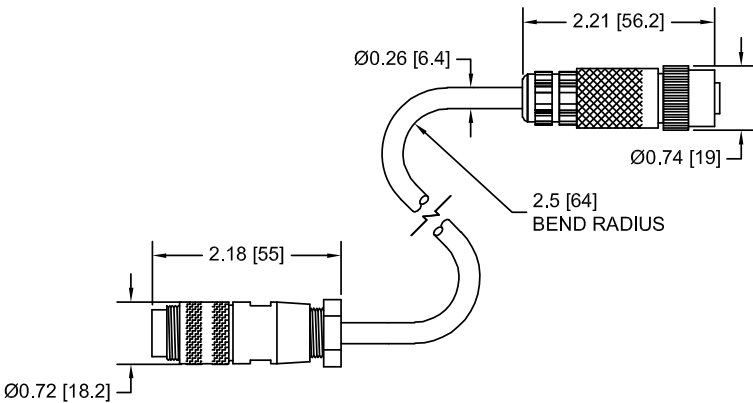

## SB-14xx Accelerometer

Standardized with integral cable.  
 Used with all 4500 series controls.  
 xx = 11, 20, or 40  
 (cable length in feet - 3.5m, 6.0m, 12m)

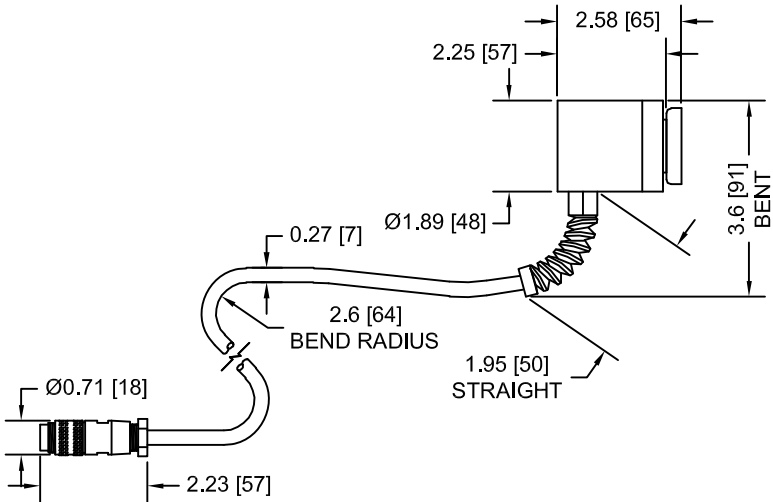

## SB-16xx Extension Cable

Extends cable runs for SB-14xx Vibration Sensors.

xx = 11, 20, or 40 (cable length in feet - 3.5m, 6.0m, 12m)

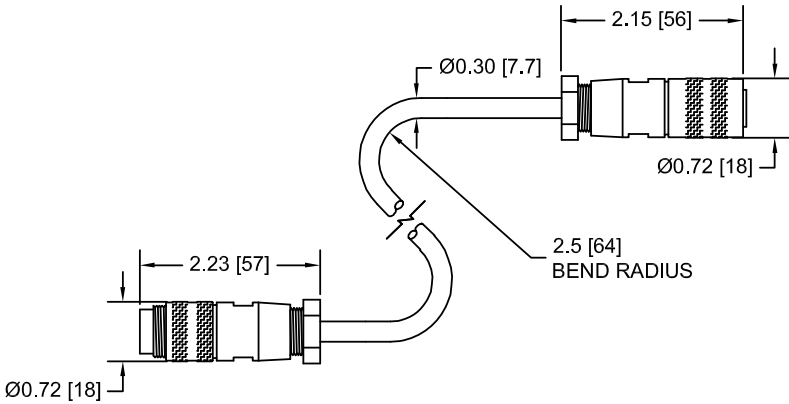

## SB-16xx-C Extension Cable

Extends cable runs for SB-14xx Vibration Sensors.

Added strain relief for bulkhead pass-through

xx = 11, 20, or 40 (cable length in feet - 3.5m, 6.0m, 12m)

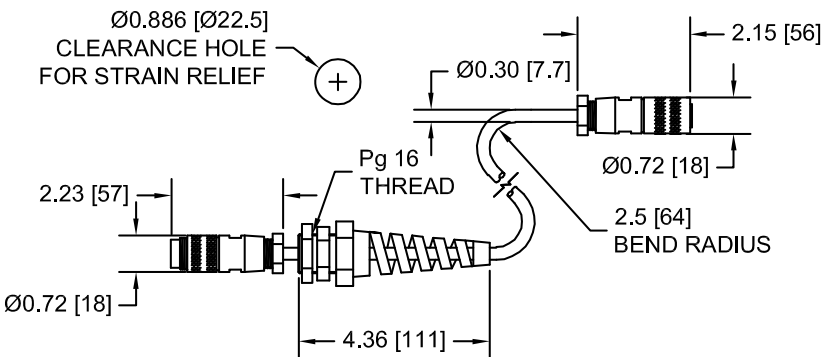

## System Components Overview

While new applications based on Hydrokompenser (HK) components are no longer offered, service and replacement parts for existing applications are available, as described in the following section.

An HK balance system uses fluid, usually grinding machine coolant, as the balance medium. A four chambered **Ring Container** is mounted on the rotating machine spindle. An injection **Nozzle** is aligned with the container so that fluid can be injected into each of the four chambers in the rotating Ring Container as needed to achieve balance. The Nozzle has four separate fluid lines which are connected to the **Valve Block**, which supplies filtered and pressure regulated fluid to the nozzle. The Valve Block is operated by the **Control**, and is connected via the **Control Cable**. The Control receives input from both the **Vibration Sensor**, and from the **Speed (RPM) Sensor**. The Speed Sensor is inductive. The Speed sensor may be integrated into the Nozzle assembly and triggered by a hole in the face of the Ring Container, or mounted separately (as pictured) and triggered by a feature located elsewhere on the Ring Container or machine pulley.

### System Shown With Current Revision Components

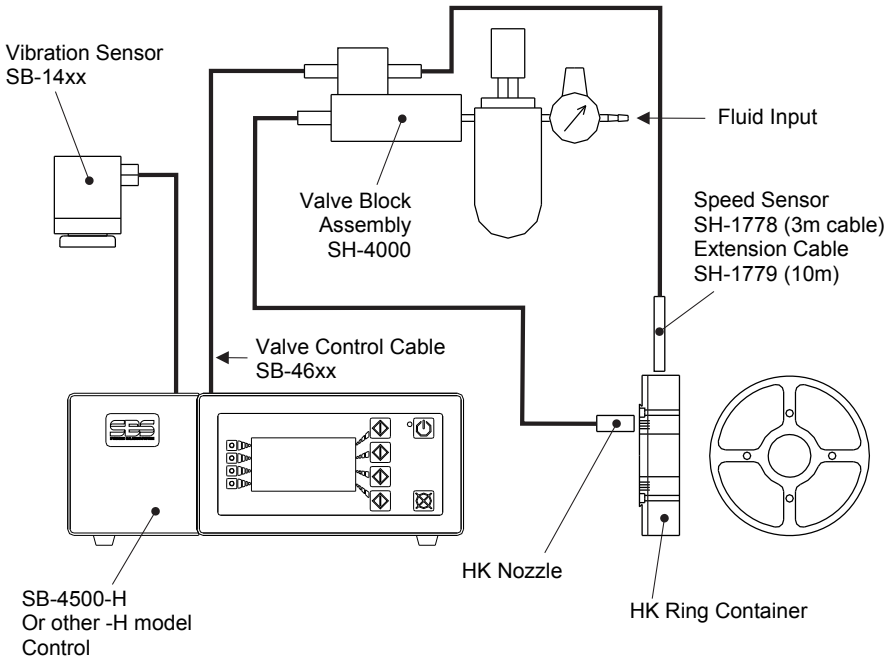

## HK-5000 System Replacement Parts

Older Hydrokompenser Systems were shipped with model HK-5000 Control. The following diagram shows replacement parts available for these older systems, including which parts are obsolete and superseded by new part numbers.

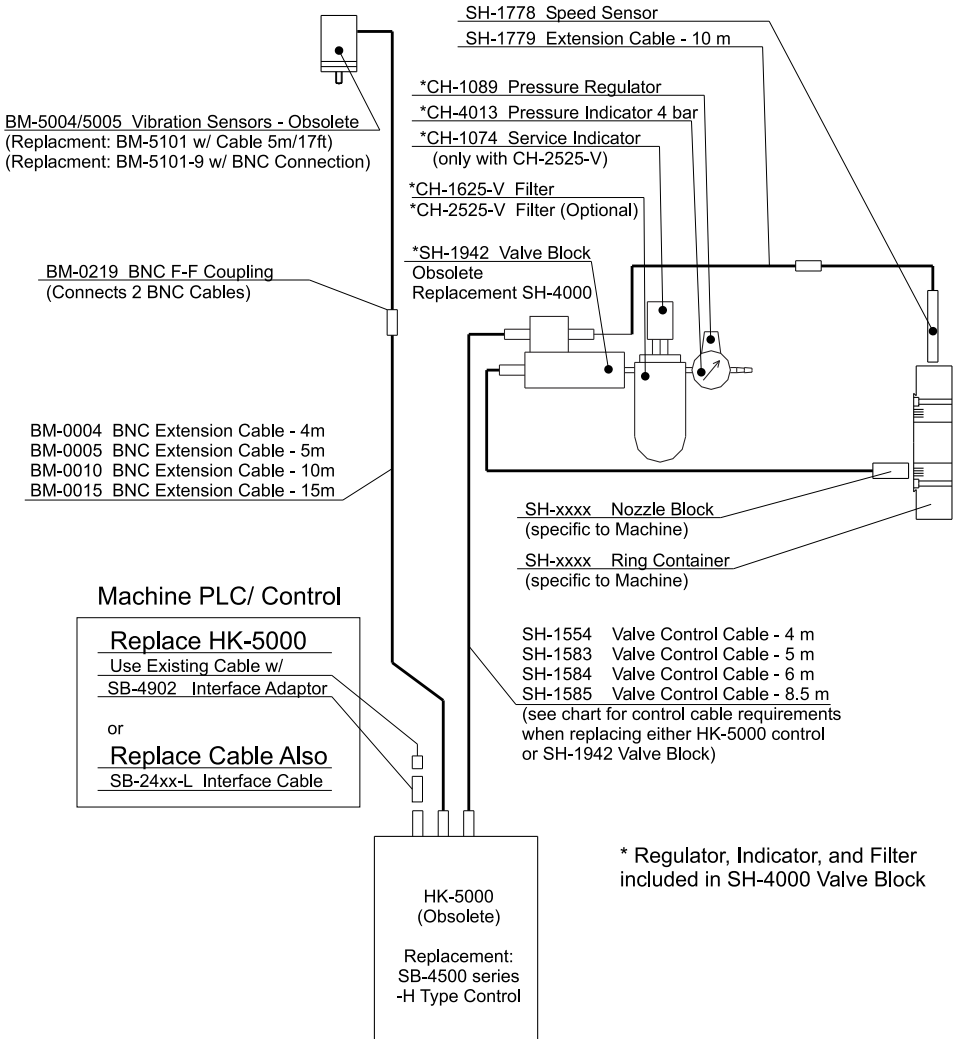

## Control / Valve Block Replacement

Control	Application/ Parts Needed to Connect	Valve Block
SB-4500-H SB-4475-H	SB-46xx Control Cable, -S connect Nozzle (fluid connector) SB-14xx Vibration Sensor	SH-4000
HK-5000	<u>Replace SH-1942 Valve Block and Control Cable</u> SH-5015 Adapter, SB-46xx Control Cable, -S connect Nozzle (fluid connector) BM-5101, BM-5101-9 Vibration Sensors	SH-4000
SB-4500-H SB-4475-H	<u>Replace HK-4410 or HK-5000 and Control Cable</u> SB-46xx-W new Control Cable, -(blank) model Nozzle (4-separate tube connect) SB-14xx Vibration Sensor	SH-1942
SB-4500-H SB-4475-H	<u>Replace HK-5000 Control</u> SB-4901 Adapter for existing Control Cable -(blank) model Nozzle (4-separate tube connect) SB-14xx Vibration Sensor	SH-1942
SB-4500-H SB-4475-H	<u>Replace HK-4410 Control:</u> SH-5010 Adapter for existing Control Cable -(blank) model Nozzle (4-separate tube connect) SB-14xx Vibration Sensor	SH-1942

## Replacement Parts for SH-1942 Valve Block

(Filter, Regulator, and Indicator sold separately, see HK-5000 System Replacement Parts Chart)

Fluid Valve Solenoid (x4)	CH-3706
4mm Tube Quick Connect (x4)	CH-0246

## Standard Nozzles – Flat Type

w/ 4 Separate Tube Connect – used with SH-1942 Valve Block

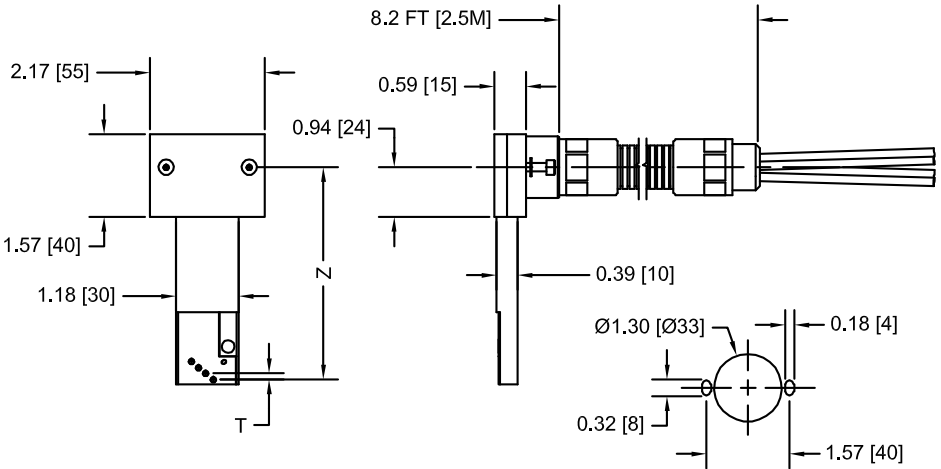

**Model List** (IF=1 – RPM Sensor Included) (IF=0 – RPM Sensor NOT Included)

Size	Pitch T=3mm		Pitch T=5mm		Z = mm
	IF=1	IF=0	IF=1	IF=0	
1	<b>SH-0948</b>	<b>SH-1168</b>	<b>SH-0945</b>	<b>SH-1165</b>	<b>60 - 80</b>
2	<b>SH-0949</b>	<b>SH-1169</b>	<b>SH-0946</b>	<b>SH-1166</b>	<b>90 - 110</b>
3	<b>SH-1197</b>	<b>SH-1198</b>	<b>SH-0947</b>	<b>SH-1167</b>	<b>130 - 150</b>

## Standard Nozzles – Flat Type –S Connect

w/ Fluid Quick Connector – used with SH-4000 Valve Block

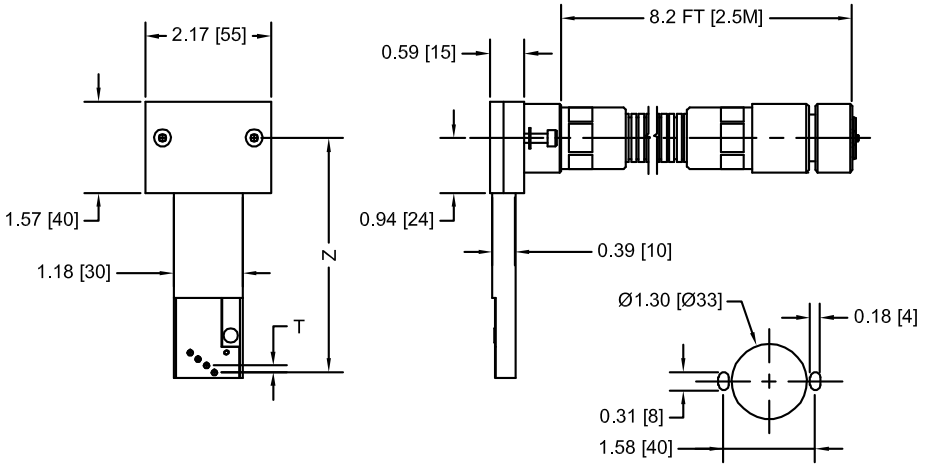

**Model List** (IF=1 – RPM Sensor Included) (IF=0 – RPM Sensor NOT Included)

Size	Pitch T=3mm		Pitch T=5mm		Z = mm
	IF=1	IF=0	IF=1	IF=0	
1	SH-0948-S	SH-1168-S	SH-0945-S	SH-1165-S	60 - 80
2	SH-0949-S	SH-1169-S	SH-0946-S	SH-1166-S	90 - 110
3	SH-1197-S	SH-1198-S	SH-0947-S	SH-1167-S	130 - 150

## Standard Nozzles – Round Type

w/ 4 Separate Tube Connect – used with SH-1942 Valve Block

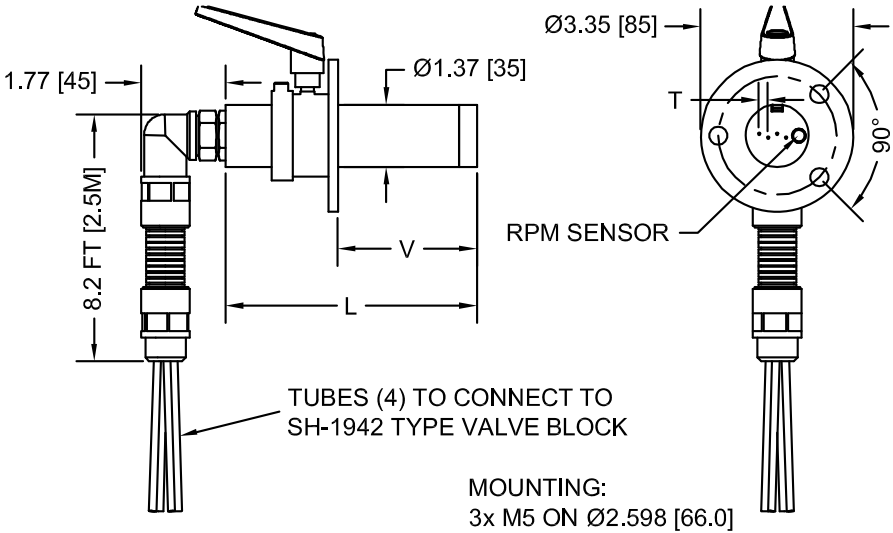

**Model List** (IF=1 – RPM Sensor Included) (IF=0 – RPM Sensor NOT Included)

Size	Pitch T=3mm		Pitch T=5mm		V = mm	L = mm
	IF=1	IF=0	IF=1	IF=0		
1	<b>SH-0943</b>	<b>SH-1163</b>	<b>SH-0940</b>	<b>SH-1160</b>	0 - 50	90
2	<b>SH-0944</b>	<b>SH-1164</b>	<b>SH-0941</b>	<b>SH-1161</b>	0 - 100	140
3	<b>SH-1273</b>	<b>SH-1274</b>	<b>SH-0942</b>	<b>SH-1162</b>	0 - 150	190

## Standard Nozzles – Round Type –S Connect

w/ Fluid Quick Connector – used with SH-4000 Valve Block

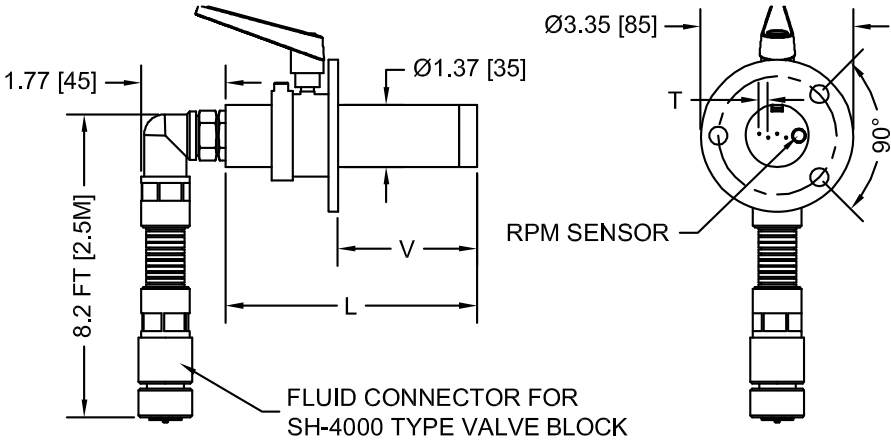

MOUNTING:  
3x M5 ON Ø2.598 [66.0]

**Model List** (IF=1 – RPM Sensor Included) (IF=0 – RPM Sensor NOT Included)

Size	Pitch T=3mm		Pitch T=5mm		V = mm	L = mm
	IF=1	IF=0	IF=1	IF=0		
1	SH-0943-S	SH-1163-S	SH-0940-S	SH-1160-S	0 - 50	90
2	SH-0944-S	SH-1164-S	SH-0941-S	SH-1161-S	0 - 100	140
3	SH-1273-S	SH-1274-S	SH-0942-S	SH-1162-S	0 - 150	190

## SH-4000 Valve Block

Includes Filter, Regulator, and Indicator – use with –S Connect Nozzles

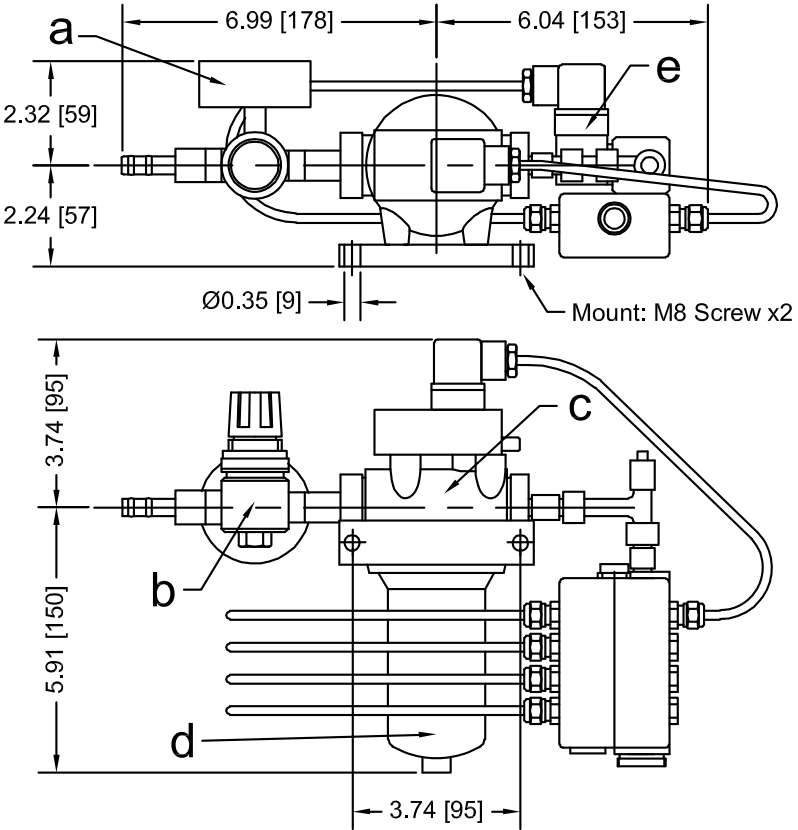

	Description	Replacement Part
a	Fluid Pressure Indicator (0-4 bar)	CH-4013
b	Fluid Pressure Regulator	CH-1071
c	Complete Filter Housing w/ Service Indicator	CH-0080
d	Filter Element (25µm screen)	CH-0080-E
e	Fluid Valve Solenoid (x4)	CH-4001

## SH-1778 Speed Sensor

Inductive sensor mounts separate from Nozzle – Includes 3m cable  
(older models used grey flex hose in place of black cable)

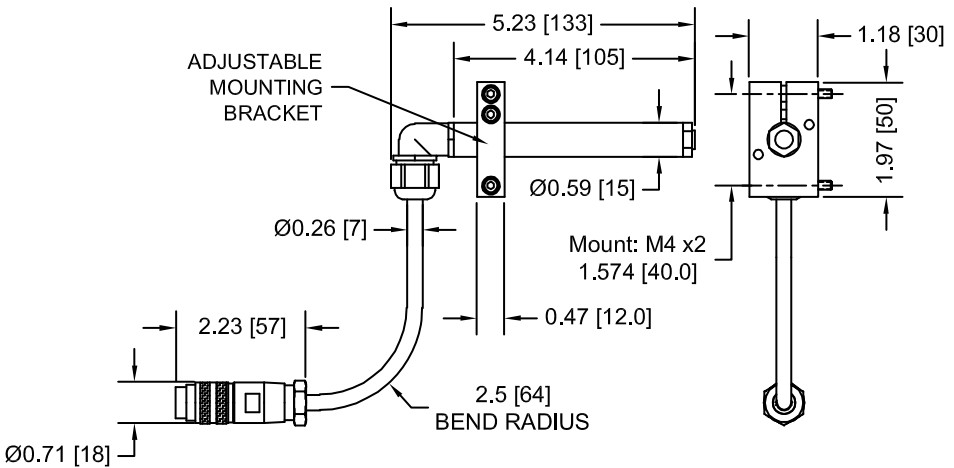

## Speed Sensor Extension Cable (not pictured)

SH-1779 – 10m extension cable

SH-1779-5 – 5m extension cable